

CALI 14

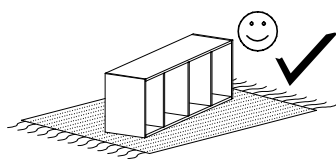

Narzędzia potrzebne do montażu

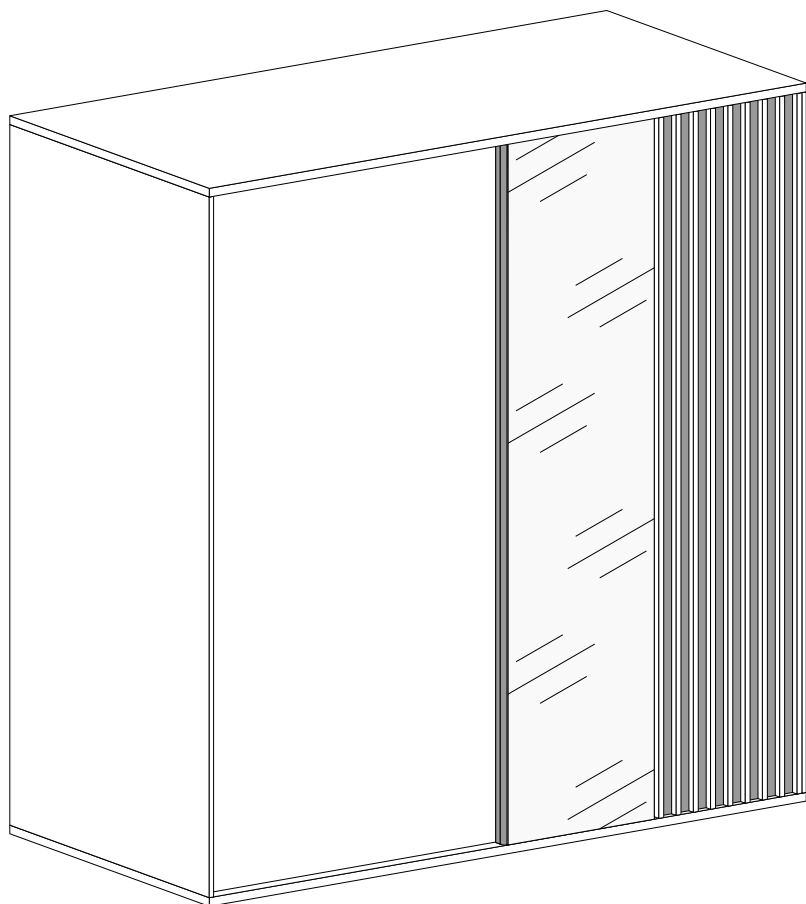

Nr	Nazwa elementu	D[mm]	S[mm]	G[mm]	Ilość
1	Bok Lewy	2096	600	16	1
2	Bok Prawy	2096	600	16	1
3	Błat Górny	1790	602	32	1
4	Błat Dolny	1790	602	32	1
5	Przegroda	2096	450	16	1
6	Wieniec Wiercony	860	450	16	2
7	Wieniec	860	450	16	2
8	Przegroda Mała	1297	450	16	1
9	Półka	860	450	16	2
10	Półka	450	422	16	6
11	Kapak	2118	890	2,5	2
12	Drzwi	2060	900	16	1
13	Drzwi z Lamelami	2060	900	32	1
14	Stópka	100	80	16	1

UWAGA !!!

MONTOWANIE USZKODZONYCH
ELEMENTÓW POWODUJE UTRATĘ
GWARANCJI

W przypadku reklamacji proszę podać numer pakowacza znajdujący się na kartonie.

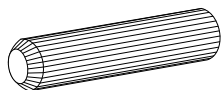

A - 28 St.

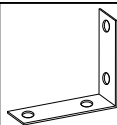

Y1 - 1 St.

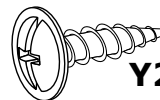

Y2 - 2 St.
3,5x16 mm



X1 - 36 St.

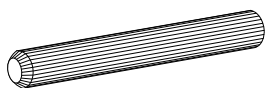

A1 - 4 St.

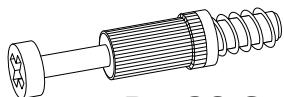

B - 28 St.



B1 - 4 St.

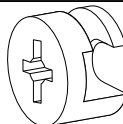

C - 36 St.

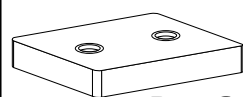

D - 6 St.

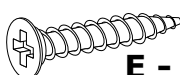

E - 12 St.
3,5x25 mm

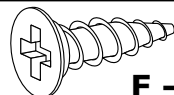

F - 64 St.
3,5x16 mm

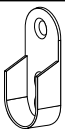

G - 2 St.



H - 1 St.



I - 4 St.

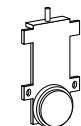

J - 4 St.

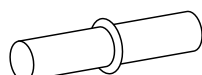

K - 32 St.

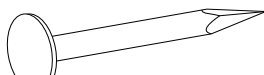

L - 120 St.

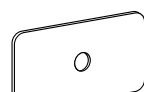

M - 20 St.



N - 2 St.

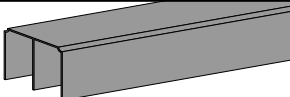

O - 1 St.

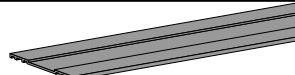

P - 1 St.

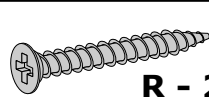

R - 2 St.
3,9x30 mm



S - 3x2,06m.

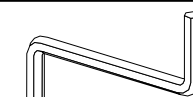

Z - 1 St.

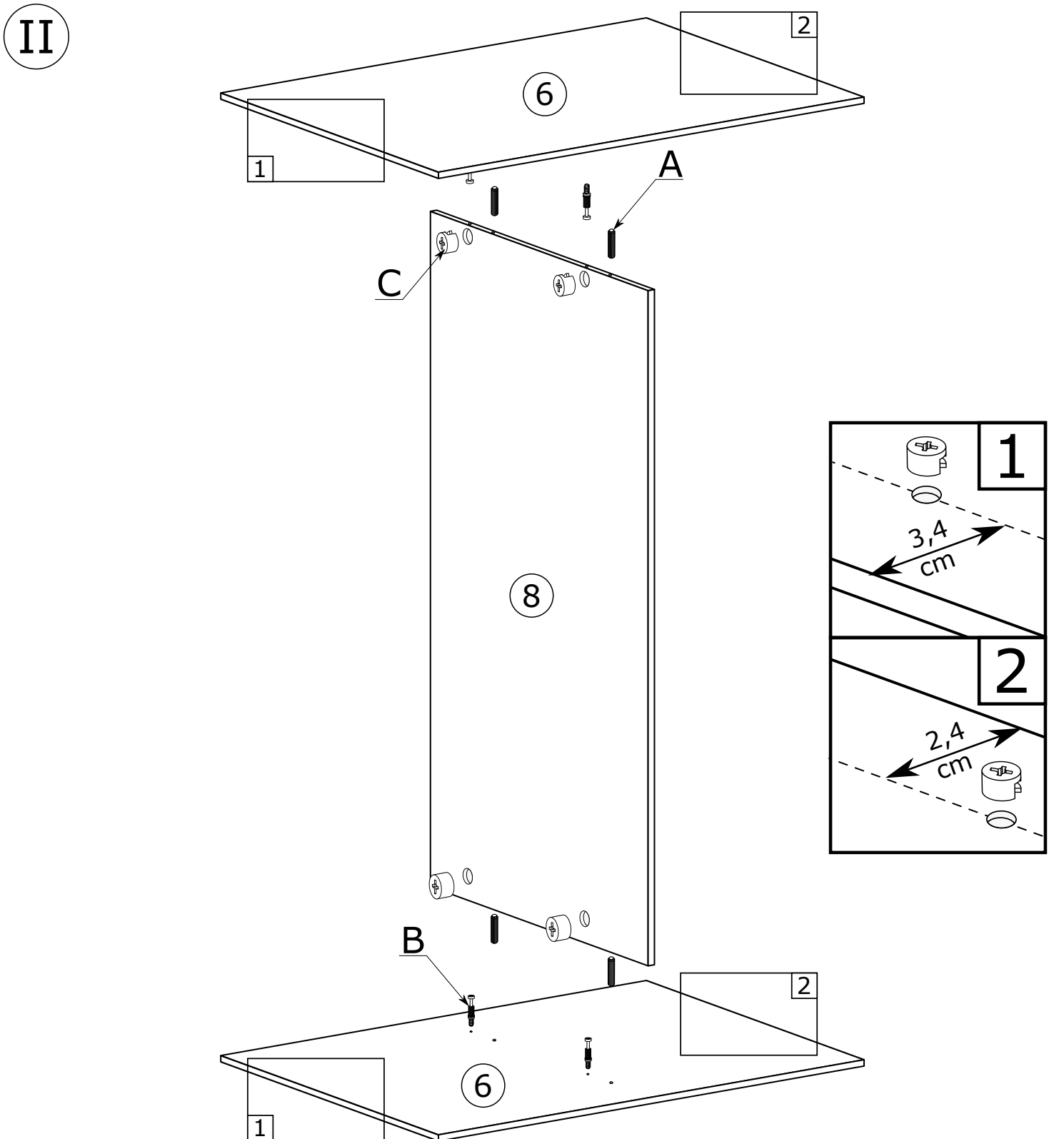
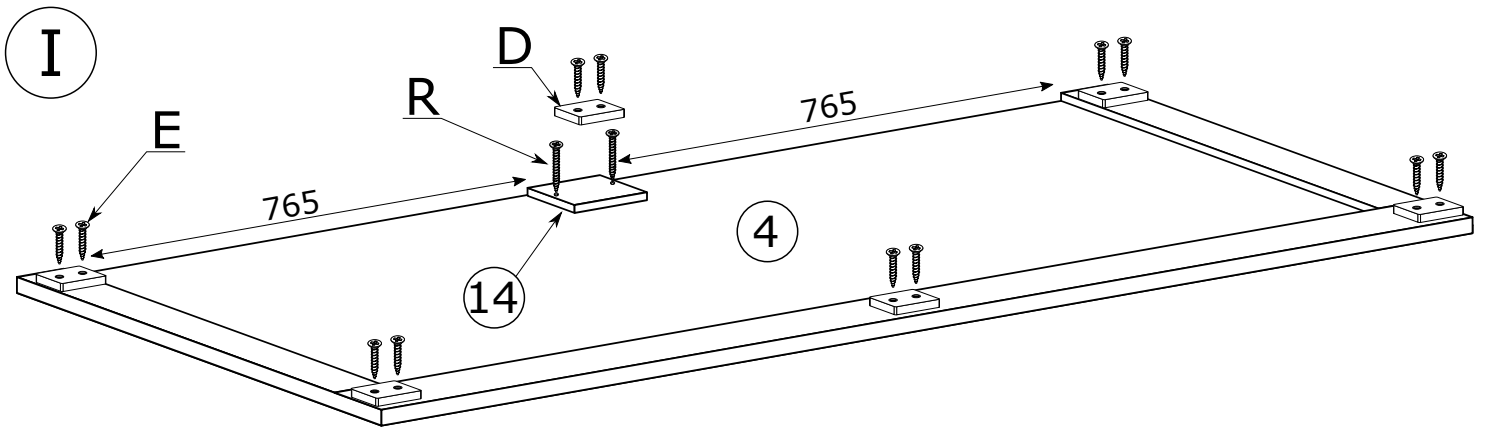

III

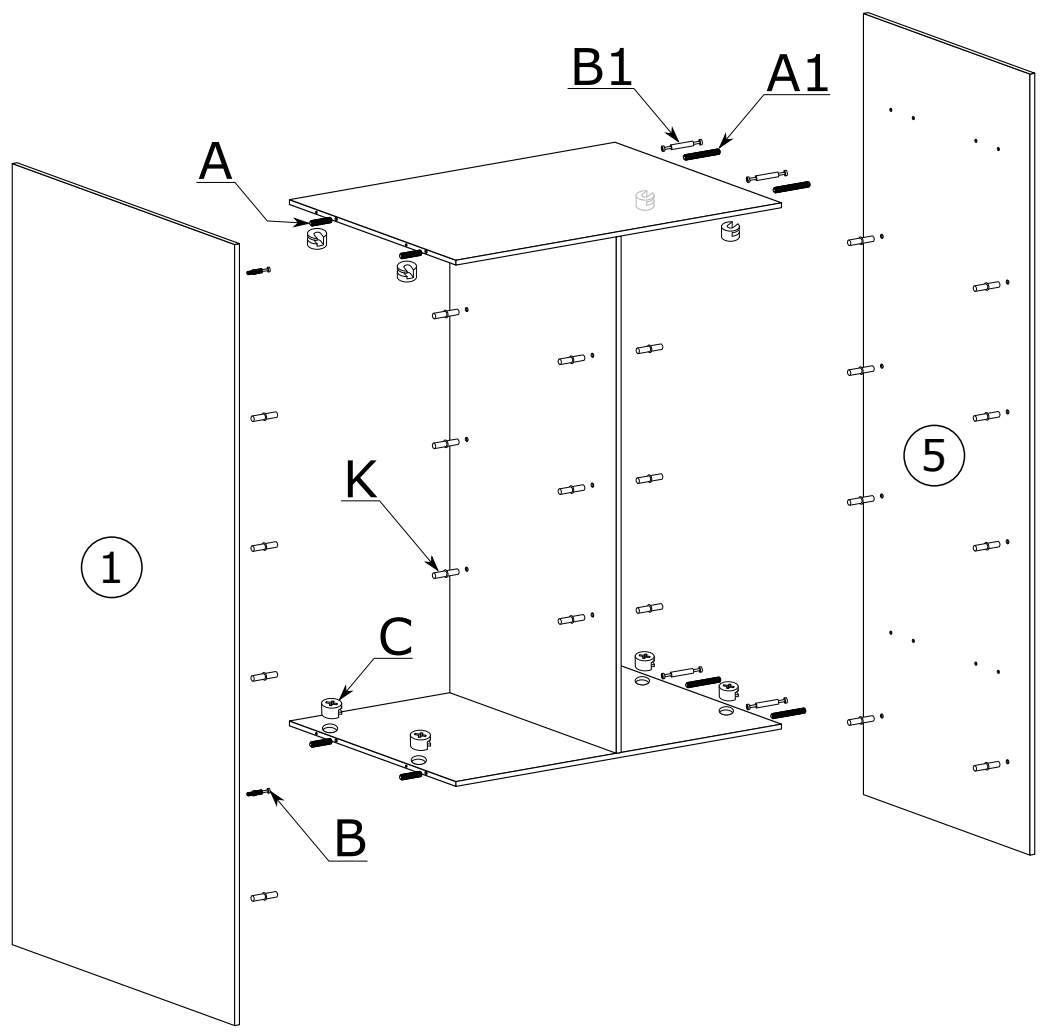

IV

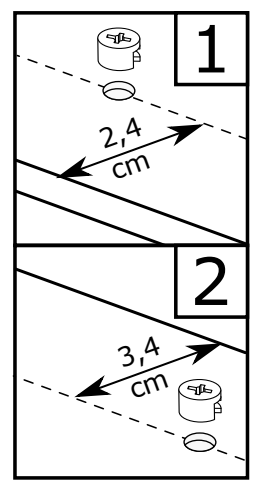
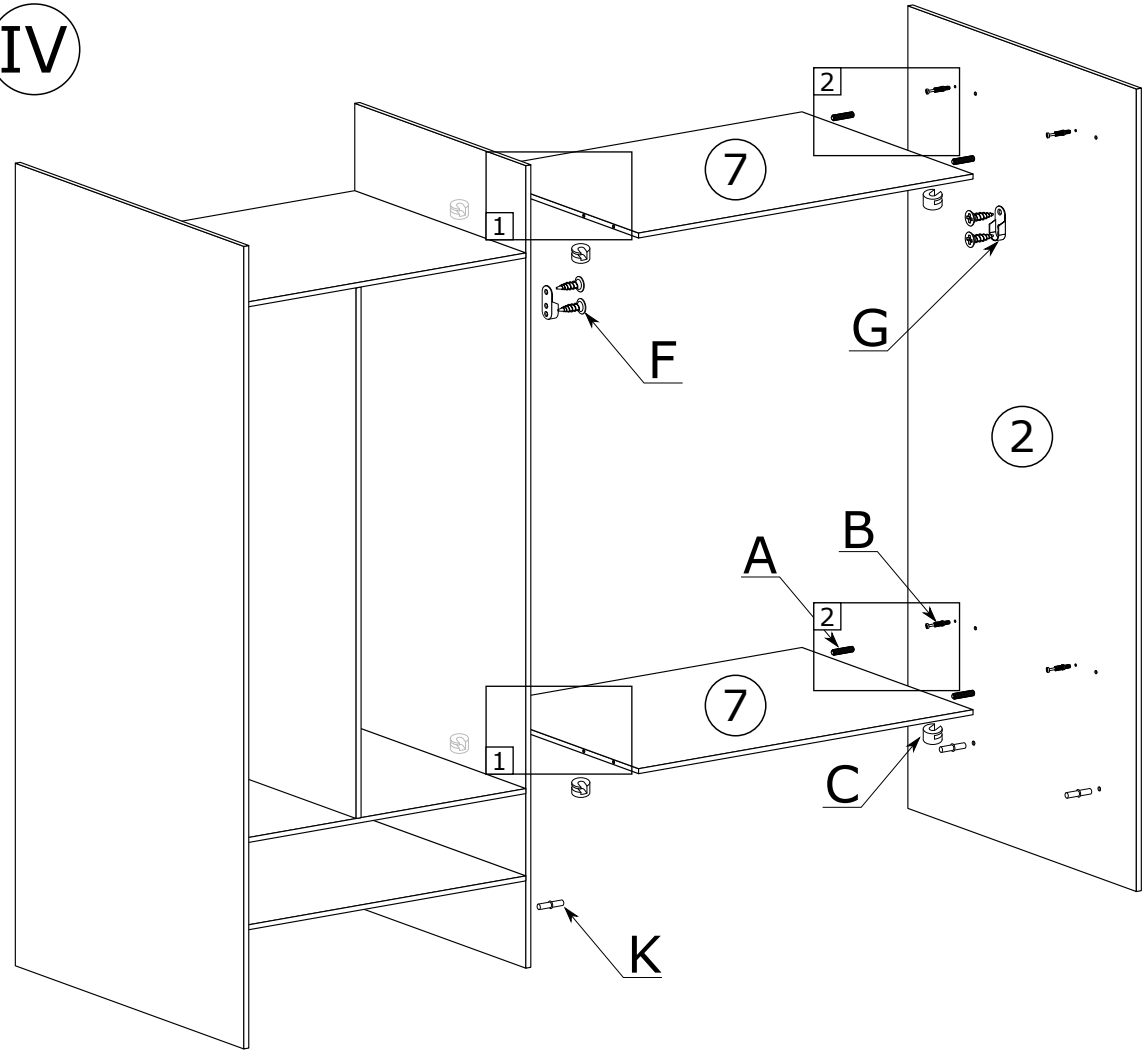

V

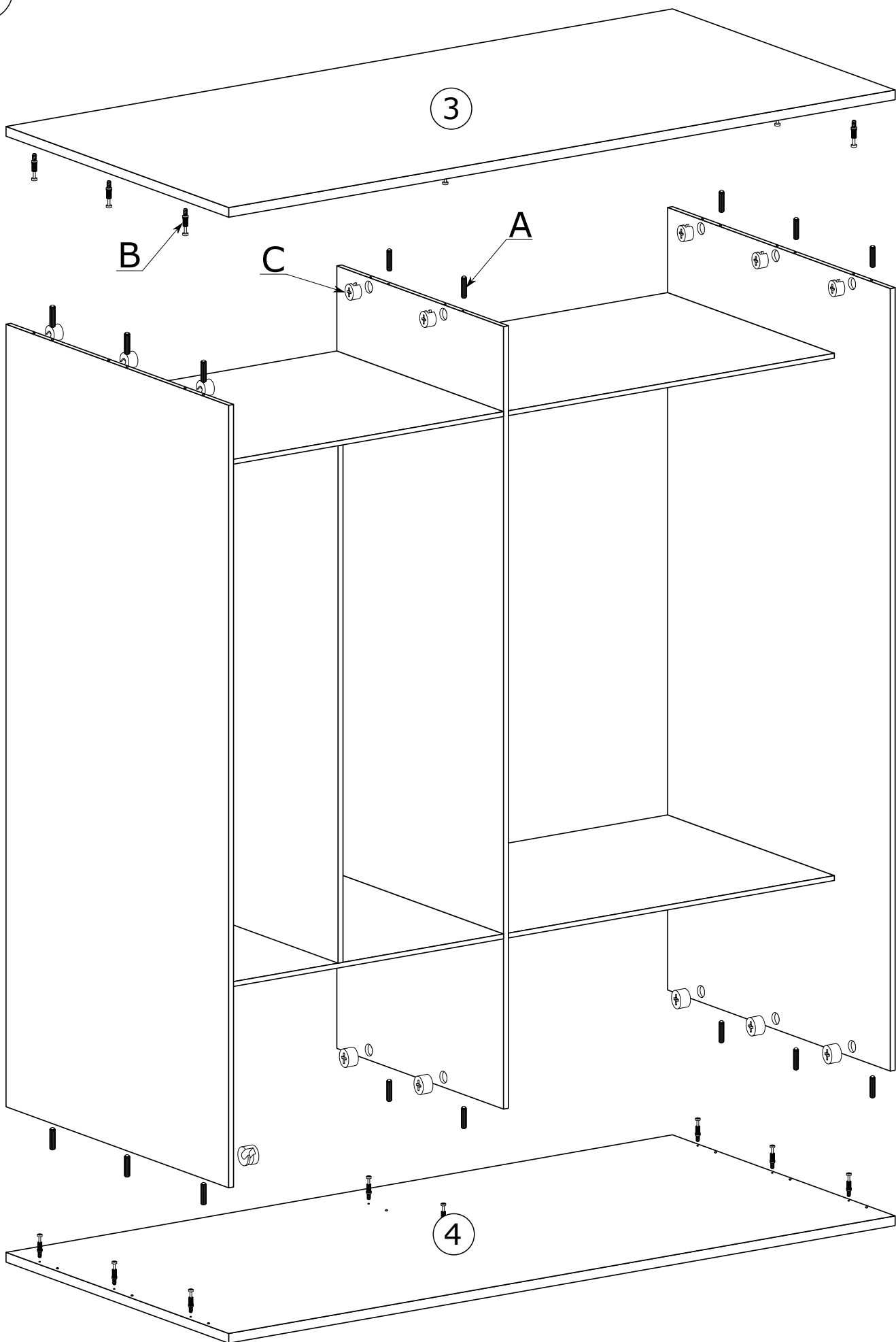

VI

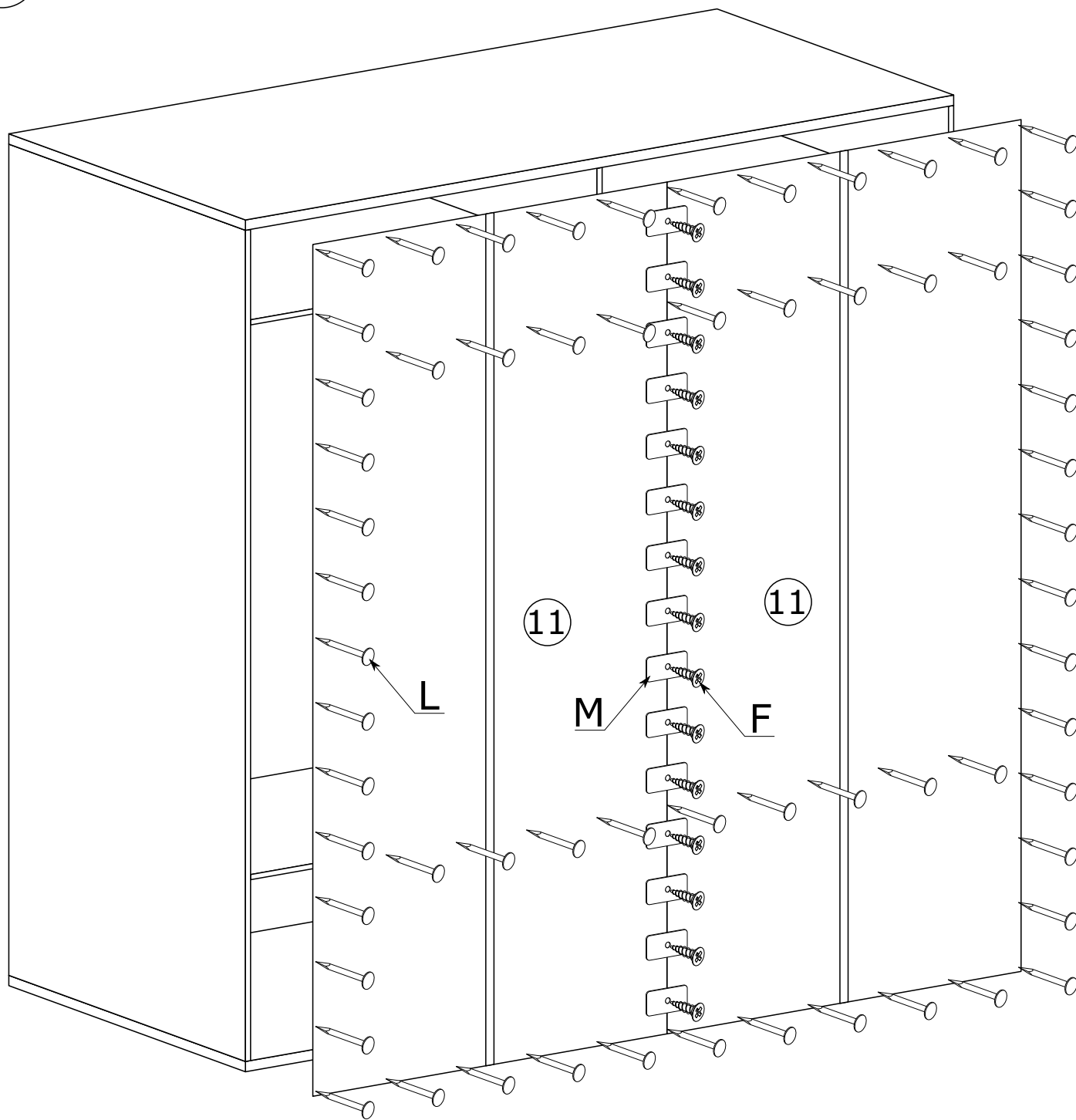

x120

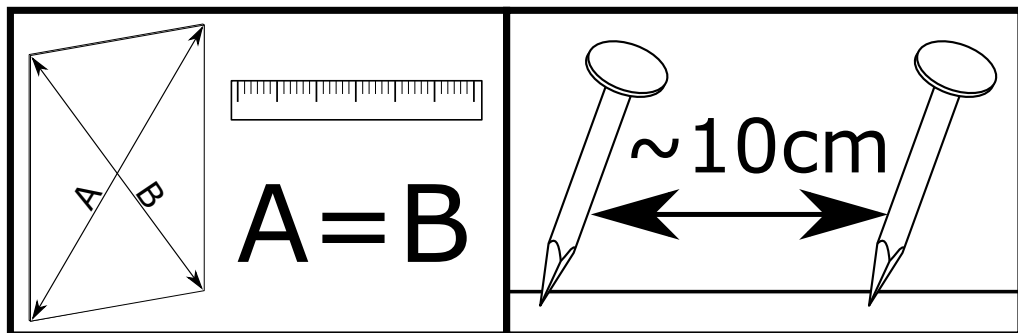
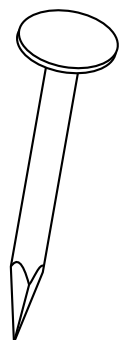

VII

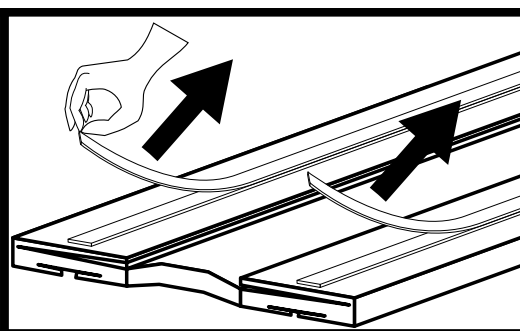
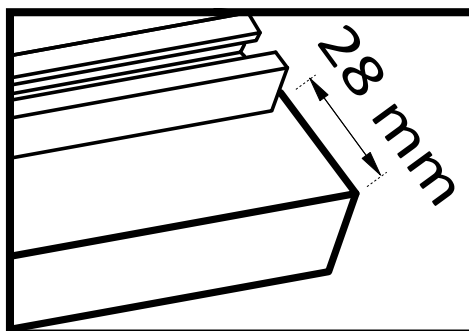
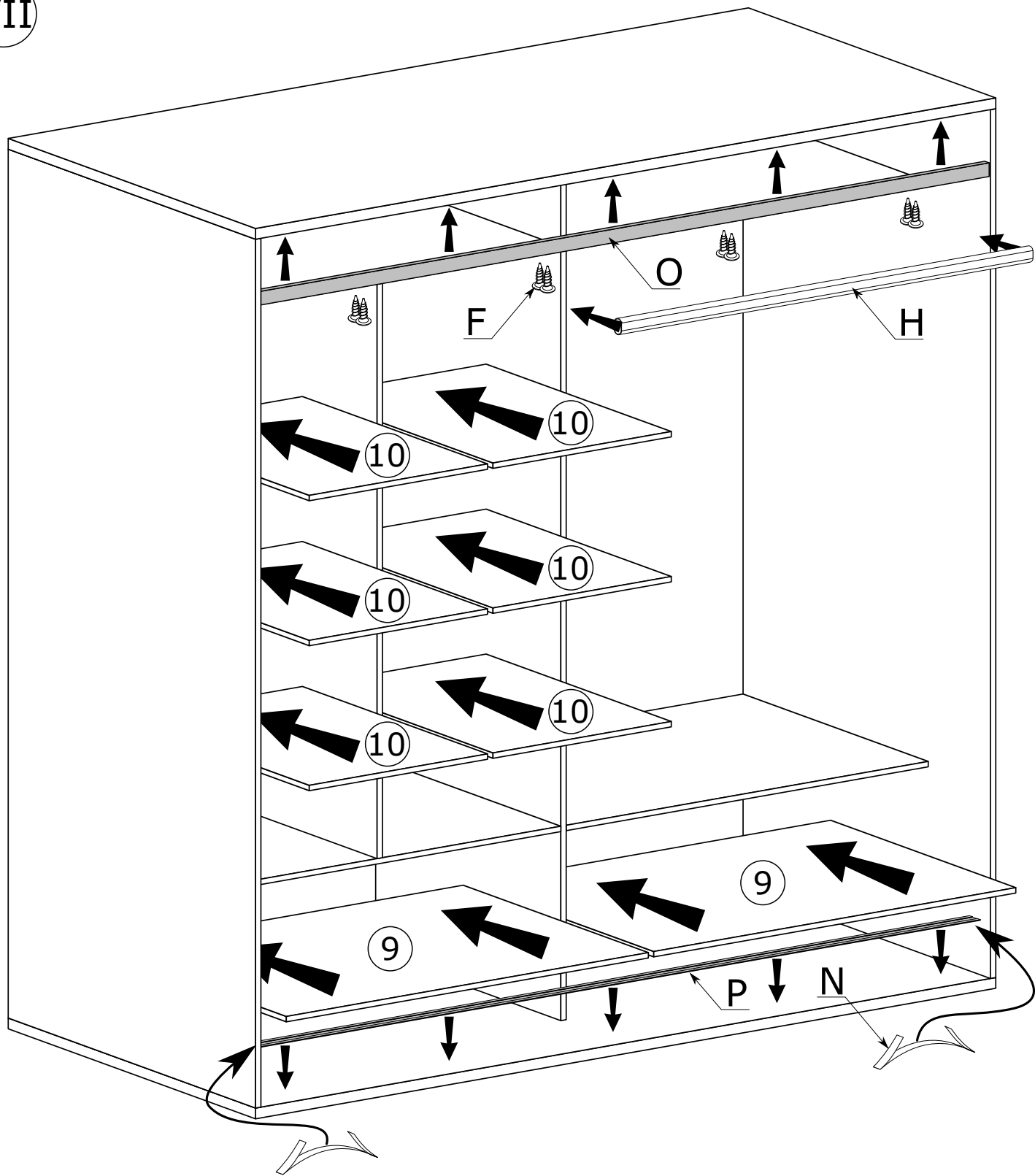

VIII

F

I

13

12

J

S

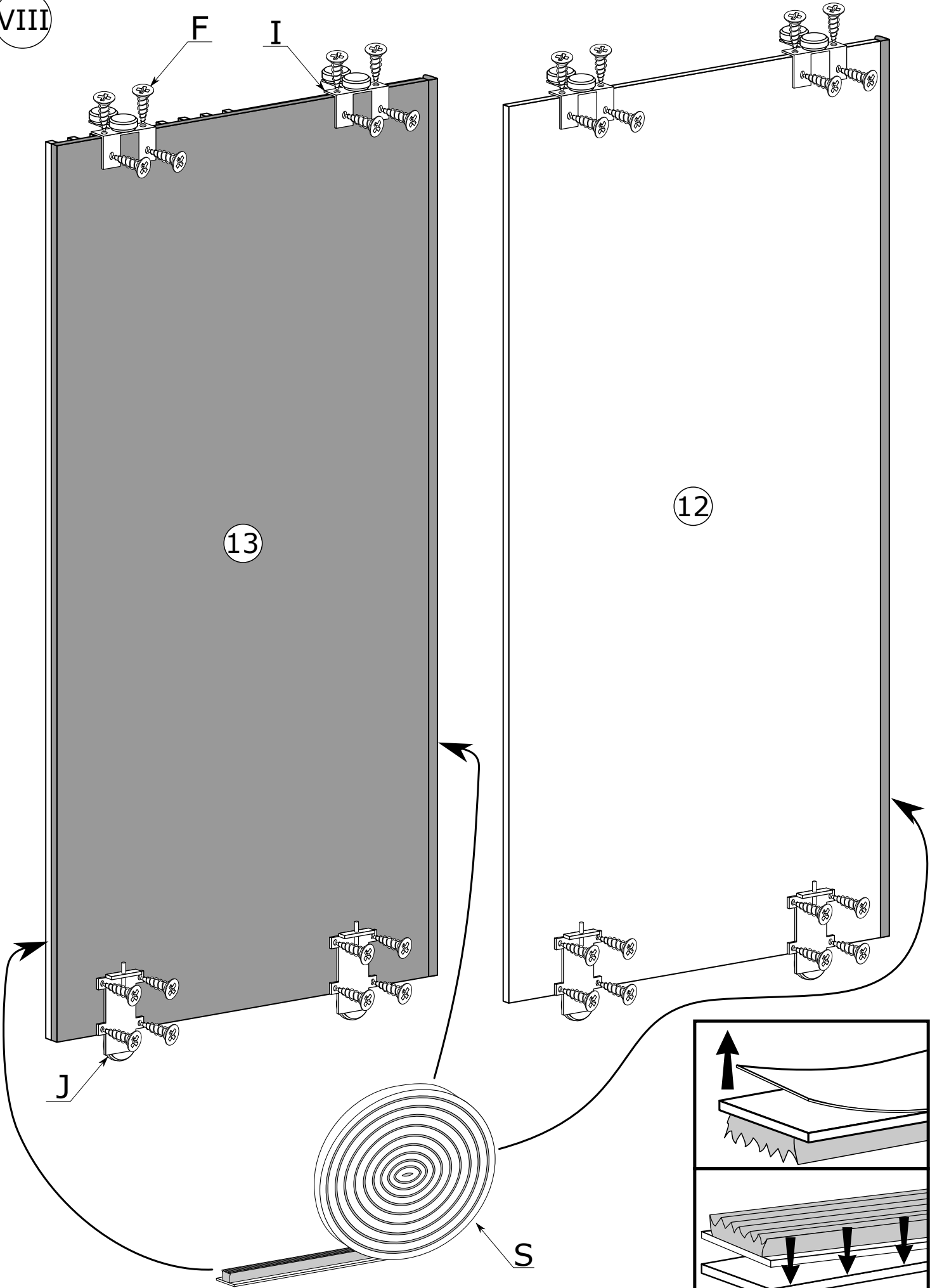
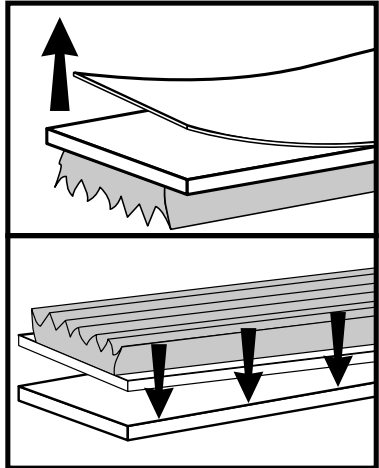

IX

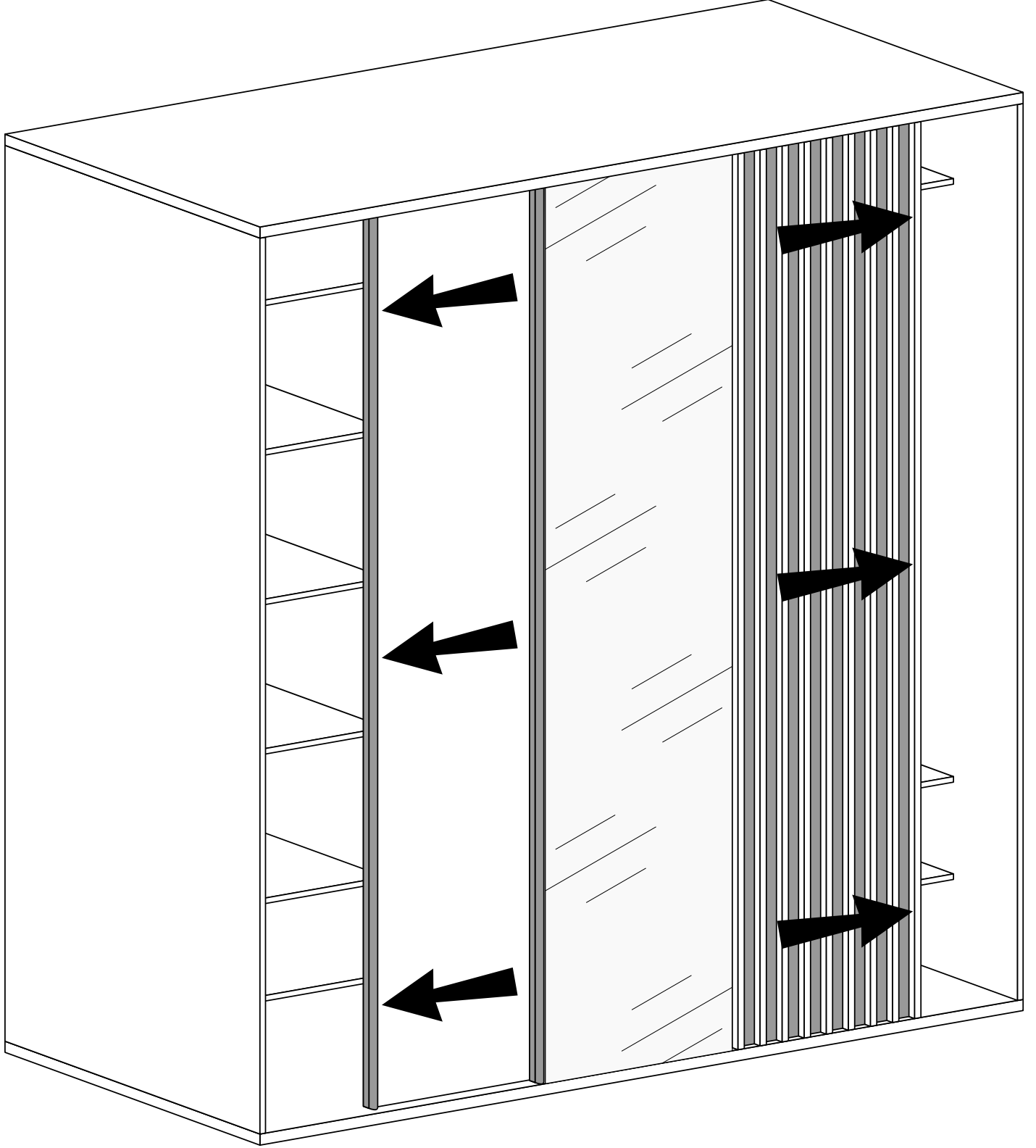

A

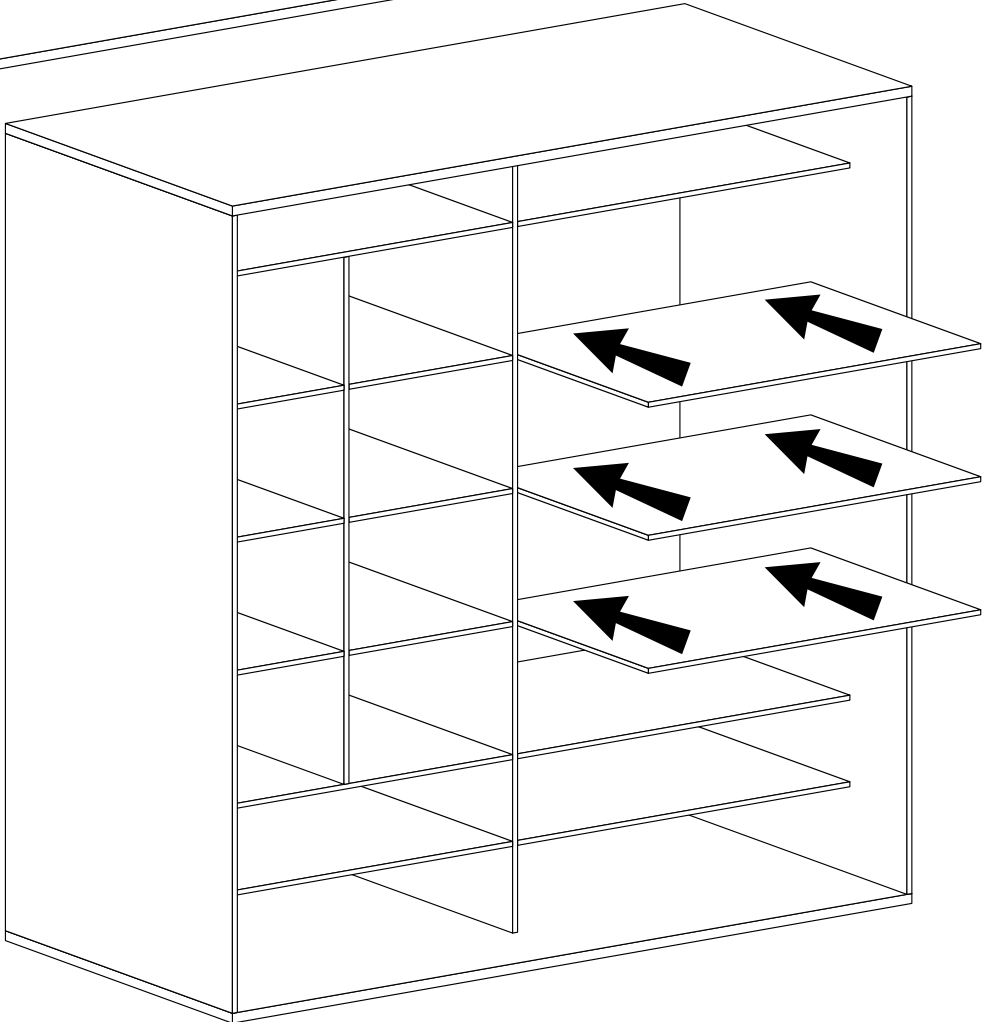
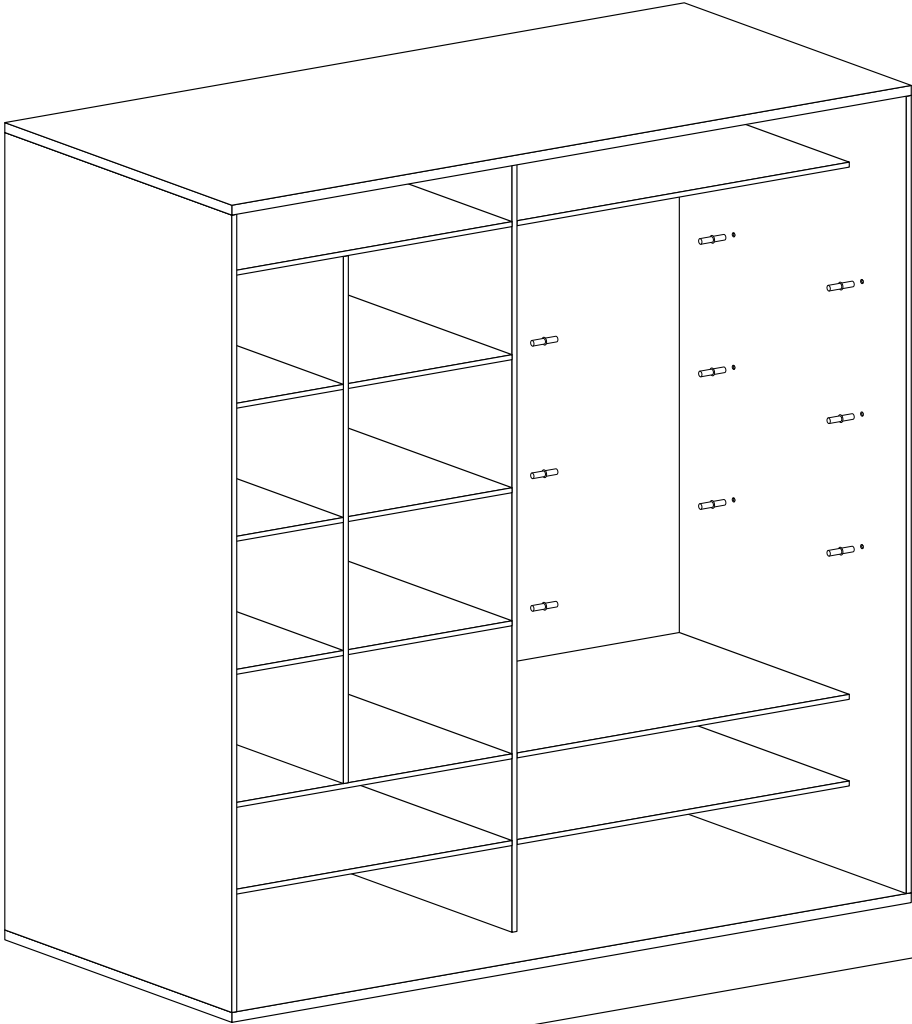

MONTAŻ KĄTOWNIKA

